

# 2118 Series

# 1.20 mm SMT Pin header

## General specifications

Insulator material	High temperature plastic, UL94V-0, color: black
Contact material	Phosphor bronze
Current rating	2 A
Voltage rating	50 V AC/DC
Contact resistance	20 mΩ max.
Insulator resistance	100 MΩ min.
Dielectrical withstanding	500 VAC for 1 min
Operating temperature	-25 °C to +85 °C
Soldering	JEDEC lead free reflow soldering process

## Mating parts series

2118-P or cable assembly



## Mechanical dimensions

Unit: mm

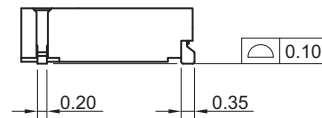
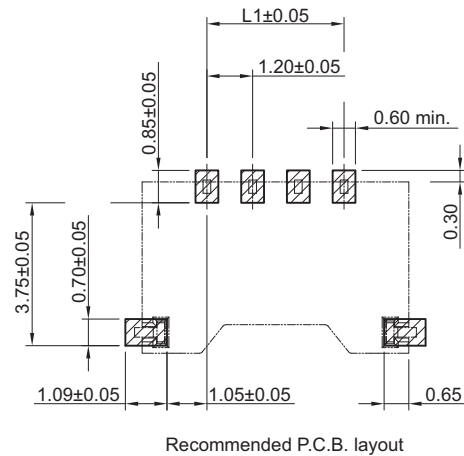
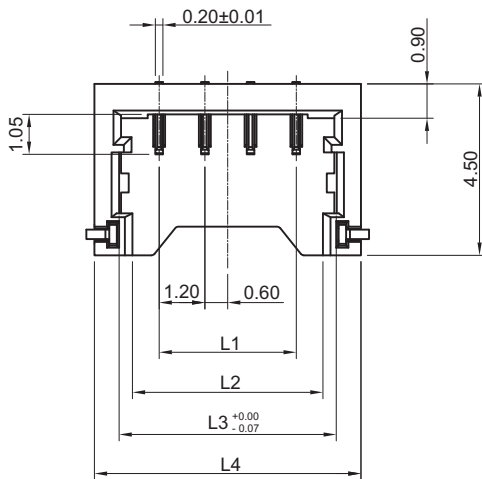

L1 = No. of contacts x 1.2 - 1.2  
 L2 = L1 + 1.4  
 L3 = L1 + 2.1  
 L4 = L1 + 3.4

### Tolerances

Linear	X	± 0.25
	.XX	± 0.15
	.XXX	± 0.10

## Part numbering guide

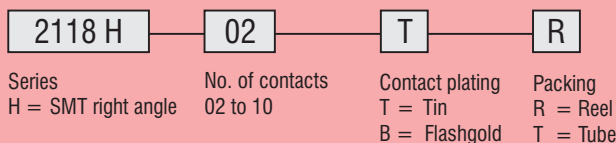

\* standard

