

1130 Series

1.27 x 1.27 mm Female Header

General specifications

Insulator material	Nylon-9T, UL94V-0, color: black
Contact material	Copper alloy
Current rating	1 A
Contact resistance	20 mΩ max.
Insulator resistance	1000 MΩ min.
Dielectrical withstanding	500 VAC for 1 min
Operating temperature	-40 °C to +105 °C
Soldering	Lead free wave soldering process
Mating parts series	
1100, 1111, 1150, 1151, 1161	

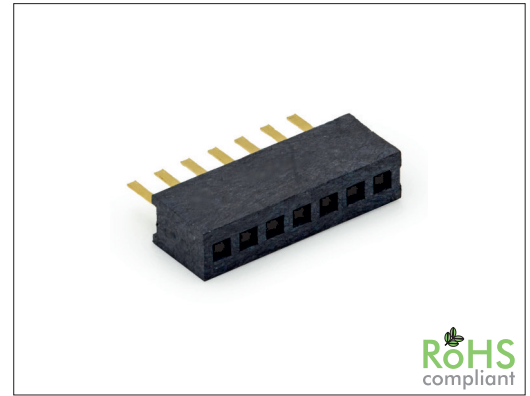

Mechanical dimensions

Unit: mm

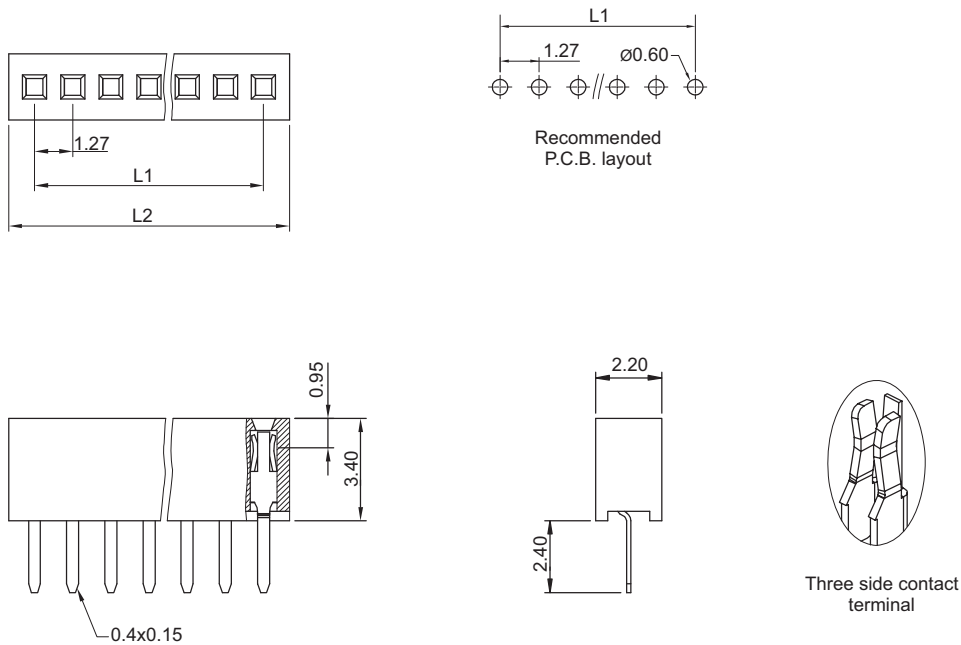

$$L1 = (\text{No. of contacts} - 1) \times 1.27$$

$$L2 = \text{No. of contacts} \times 1.27 + 0.40$$

Tolerances		
Linear	X	± 0.38
	.XX	± 0.25

Part numbering guide

1130 S — 02 — B

Series
S = THT straight

No. of contacts
02 to 50

Contact plating
B = Flashgold
E = 10 μm gold
F = 15 μm gold
J = 30 μm gold

* standard

