

# 2159 Series

# 1.50 mm Board-in Connector and Terminal

### General specifications

Insulator material	Nylon 66, UL94V-0, color: nature
Contact material	Phosphor bronze, plating: tin
Current rating	1 A
Voltage rating	200 V AC/DC
Contact resistance	20 mΩ max.
Insulator resistance	500 MΩ min.
Dielectrical withstanding	500 VAC for 1 min
Operating temperature	-25 °C to +85 °C
Soldering	Lead free wave soldering process

### Mating parts series

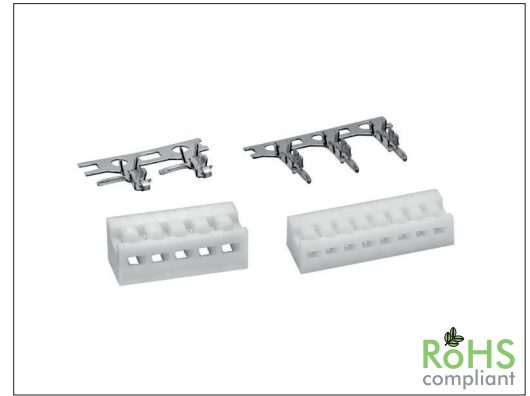

### Mechanical dimensions

Unit: mm

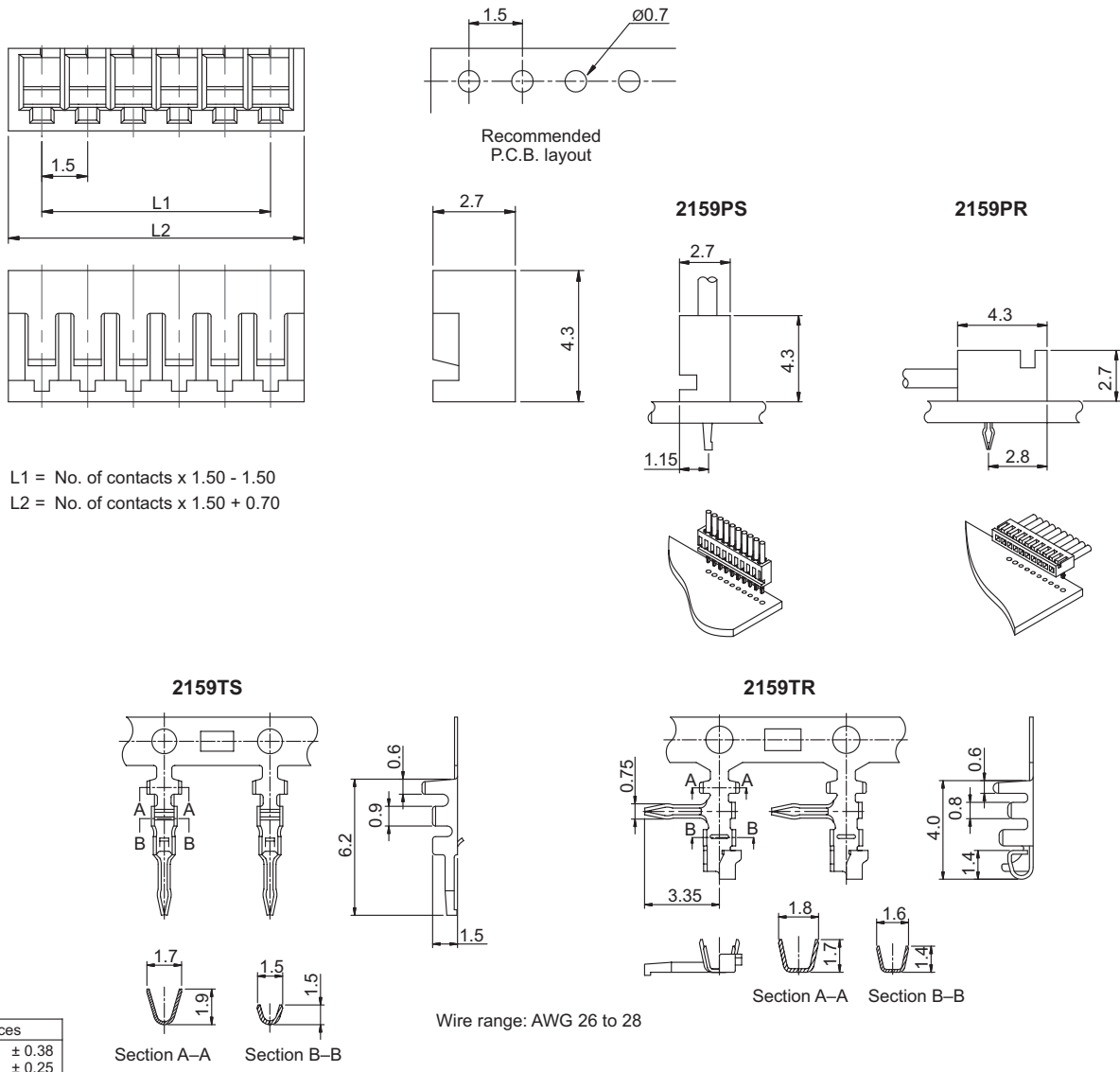

### Part numbering guide

2159 PS

02

Series  
PS = Housing straight  
PR = Housing right angle  
TS = Terminal straight  
TR = Terminal right angle

No. of contacts  
02 to 15  
(leave blank for terminals)

\* standard

