

# SW-TMG/TJG Series SMT Tactile Switch 3.7 x 6 mm

## General specifications

Housing material	Nylon, UL94V-0, color: black
Actuator material	Nylon, UL94V-0
Contact material	Brass, plating: silver
Current rating	50 mA
Voltage rating	12 VDC
Contact resistance	100 mΩ max.
Insulator resistance	100 MΩ min. @ 500 VDC
Dielectrical withstanding	300 VAC for 1 min
Operating temperature	-25 °C to +70 °C
Operating force	see table
Durability	see table
Soldering	JEDEC lead free reflow soldering process

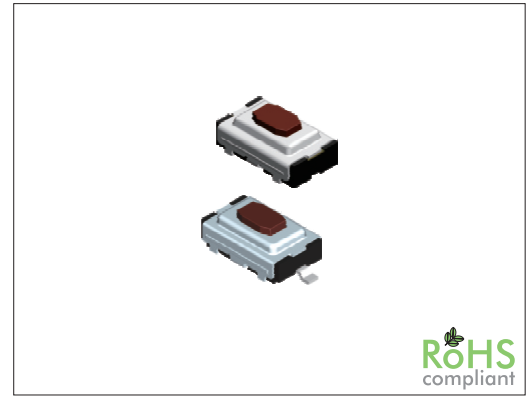

## Mechanical dimensions

Unit: mm

### SW-TMG

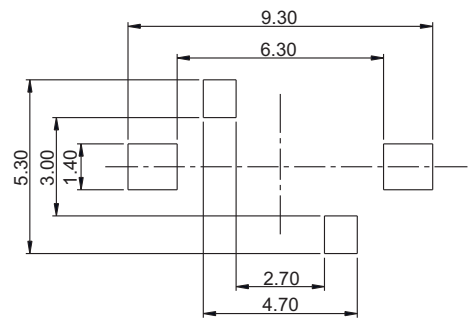
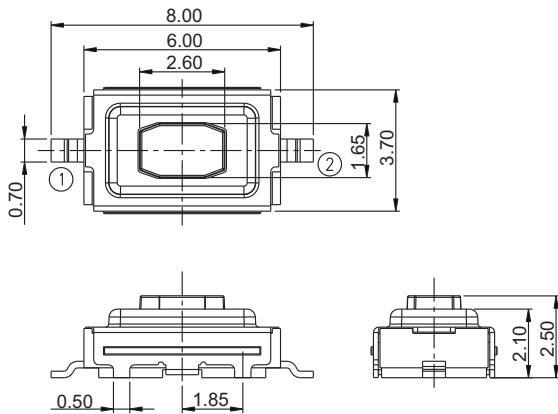

Recommended P.C.B. layout

### SW-TJG

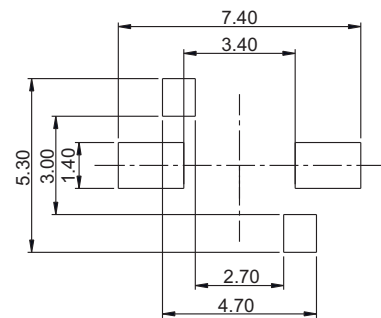
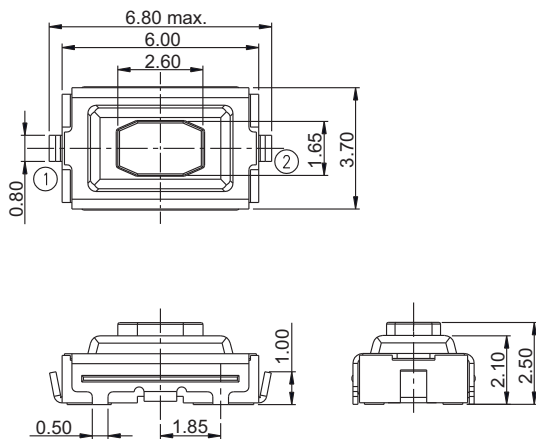

Recommended P.C.B. layout

### Circuit

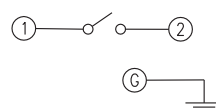

Tolerances	
Linear	± 0.20

Actuator specification				
Code	Color	Operating force	Stroke	Durability
N	Brown	160±50 gf	0.25	50000 cycles
R	Red	260±50 gf	0.25	20000 cycles

## Part numbering guide

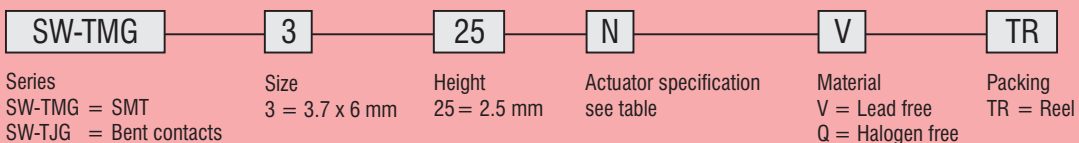

\* standard

