

2201 Series 2.00 mm Pin Header

General specifications

Insulator material	Nylon 66, UL94V-0, color: nature
Contact material	Brass
Current rating	4 A
Voltage rating	125 V AC/DC
Contact resistance	10 mΩ max.
Insulator resistance	1000 MΩ min.
Dielectrical withstanding	1000 VAC for 1 min
Operating temperature	-30 °C to +105 °C
Soldering	Lead free wave soldering process

Mating parts series



Mechanical dimensions

Unit: mm

2201S

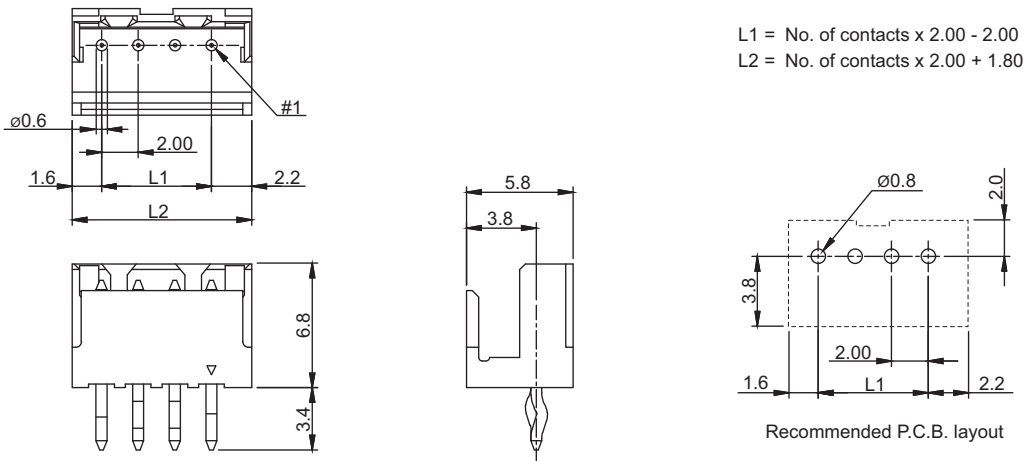

2201R

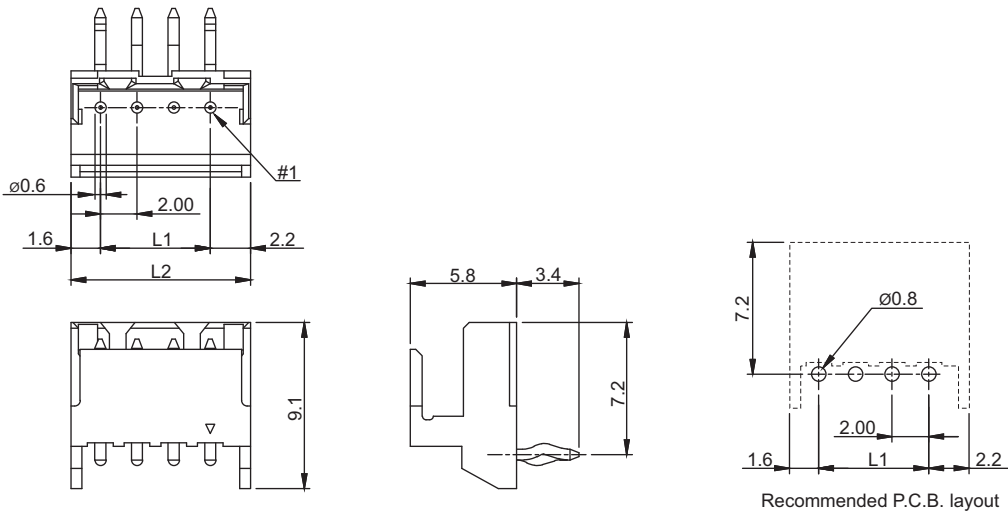

Tolerances

Linear	X	± 0.25
	.XX	± 0.12
	.XXX	± 0.08

Part numbering guide

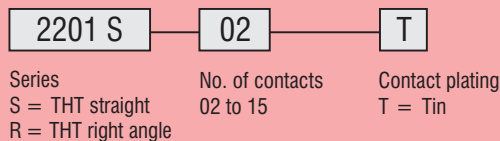

* standard

