

2514 Series

5.08 mm HDD-PS Pin Header

General specifications

Insulator material	Nylon 66, UL94V-2, color: nature
Contact material	Brass, plating: tin
Current rating	10 A
Voltage rating	250 V AC/DC
Contact resistance	10 mΩ max.
Insulator resistance	500 MΩ min.
Dielectrical withstanding	1500 VAC for 1 min
Operating temperature	-25 °C to +85 °C
Soldering	Lead free wave soldering process

Mating parts series

2514-PT or cable assembly

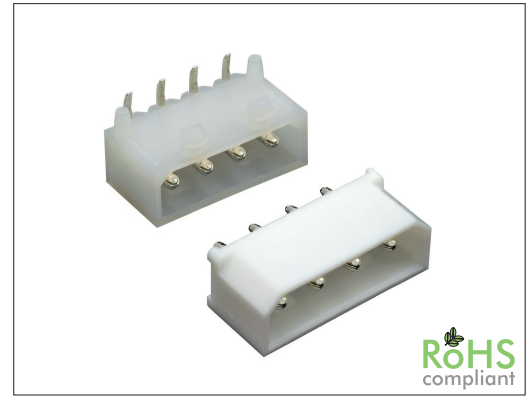

Mechanical dimensions

Unit: mm

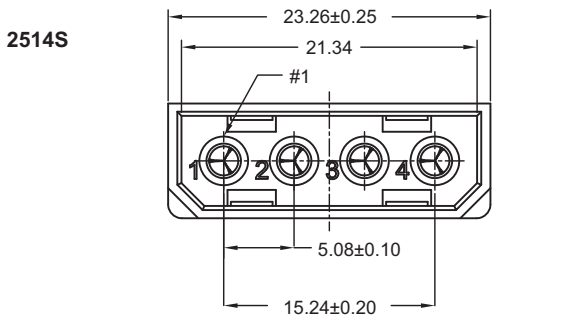

2514R

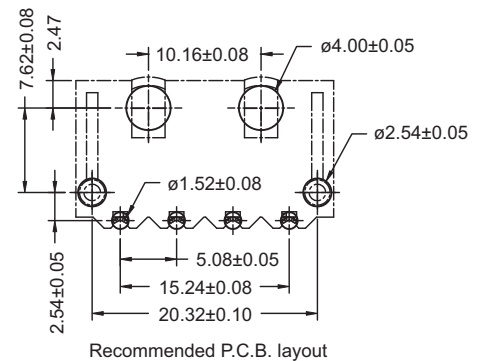
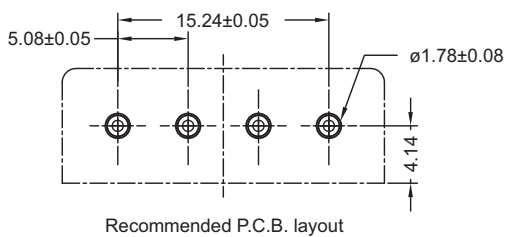
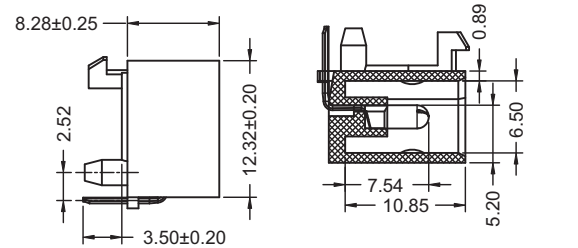
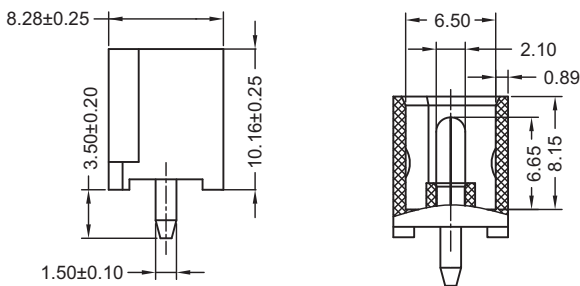
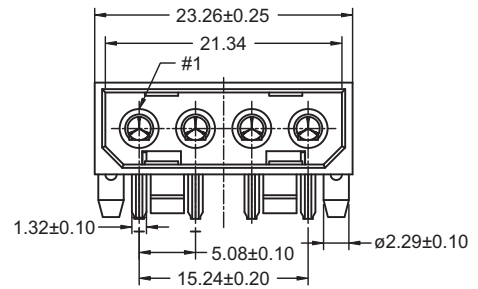

Tolerances

Linear	X	± 0.25
	.XX	± 0.15
	.XXX	± 0.05

Part numbering guide

2514 S

04

T

Series
S = THT straight
R = THT right angle

No. of contacts
04

Contact plating
T = Tin

* standard

