

# 0209 Series

# Micro SD 4.0 SMT Push-Push UHS-II

## General specifications

Insulator material	LCP, UL94V-0, color: black
Contact material	Phosphor bronze, plating: gold over nickel
Shell material	Stainless steel
Current / Voltage rating	0.5 A / 3.3 VDC
Contact resistance	100 mΩ max.
Insulator resistance	1000 MΩ min.
Dielectrical withstanding	500 VAC for 1 min
Operating temperature	-25 °C to +85 °C
Durability	5000 cycles
Soldering	JEDEC lead free reflow soldering process

## Mating parts series



## Mechanical dimensions

Unit: mm

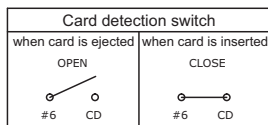
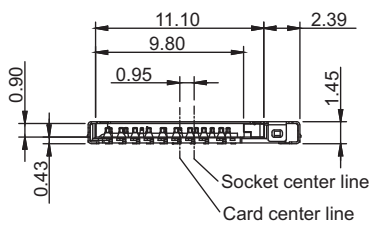
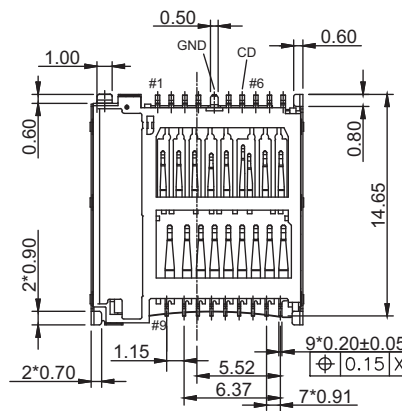
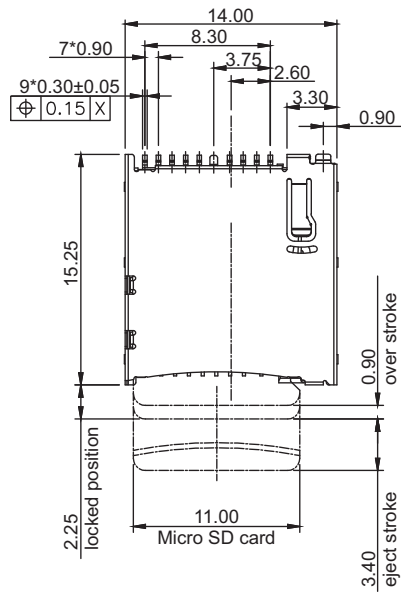

Tolerances		
Linear	X	± 0.50
	X	± 0.25
	.XX	± 0.12

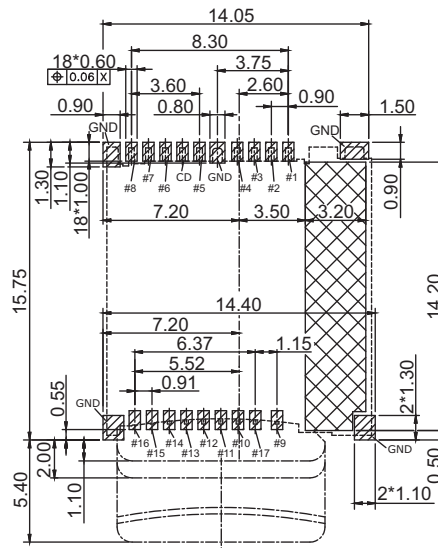

Recommended P.C.B. layout top view

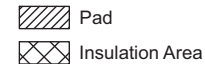

## Pin assignment

Pin	Name
1	DAT2
2	CD/DAT3
3	CMD
4	VDD
5	CLK
6	VSS
7	DAT0
8	DAT1
9	VDD2
10	VSS
11	D0+
12	D0-
13	VSS
14	D1-
15	D1+
16	VSS
17	SWIO
GND	Ground
CD	Card detect

## Part numbering guide

0209

E

R

Series

Contact plating  
E = 10 μ" gold

Packing  
R = Reel

\* standard

