

5644 Series

M12 Front Fastened Panel Mount Straight THT

General specifications

Insulator material	Nylon 66 UL94V-0, color: black
Contact material	Brass, plating: gold
Nut/Screw material	Brass, plating: nickel
Current rating, voltage rating	0.5 A, 60 VDC or 50 VAC
Contact resistance	15 mΩ max.
Insulator resistance	100 MΩ min.
Dielectrical withstanding	500 VAC for 1 min
Operating temperature	-25 °C to +85 °C
IP-Rating	IP 65
Soldering	Lead free wave soldering process

Mating parts series



Mechanical dimensions

Unit: mm

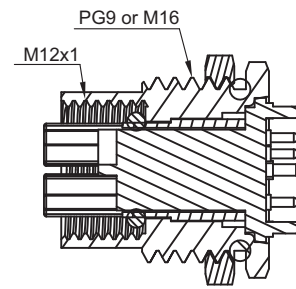
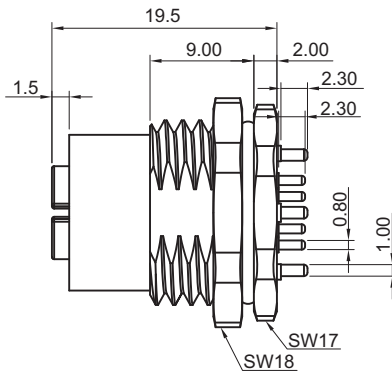
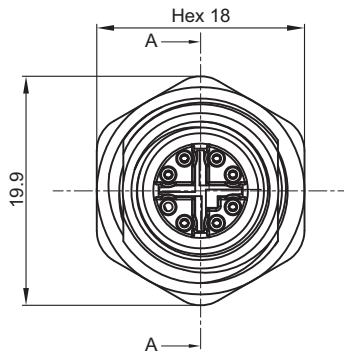

Section A-A

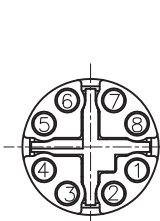

Pin assignment front view

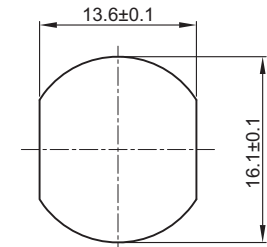

Recommended panel cut-out M16 thickness 4.0 max.

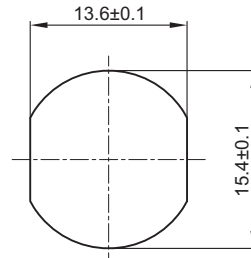

Recommended panel cut-out PG9 thickness 4.0 max.

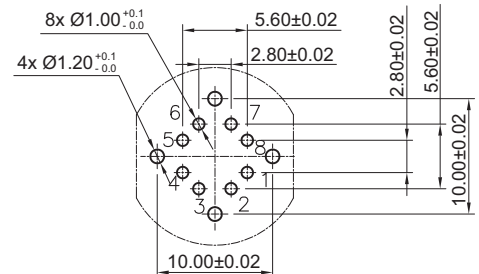

Recommend P.C.B. layout

Tolerances

Linear	X	± 0.3
	.XX	± 0.2

Part numbering guide

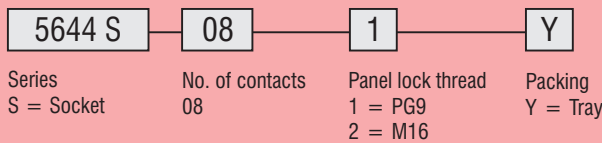

* standard

