

5100 Series

Battery Holder for CR2450

General specifications

Insulator material	PBT w/ 30% glass fiber, UL94V-0, color: black
Contact material	Phosphor bronze
Current rating	3 A
Voltage rating	250 V AC/DC
Contact resistance	30 mΩ max.
Insulator resistance	1000 MΩ min.
Dielectrical withstanding	500 VDC for 1 min
Operating temperature	-55 °C to +85 °C
Soldering	Lead free wave soldering process
Durability	50 cycles

Mating parts series



RoHS
compliant

Mechanical dimensions

Unit: mm

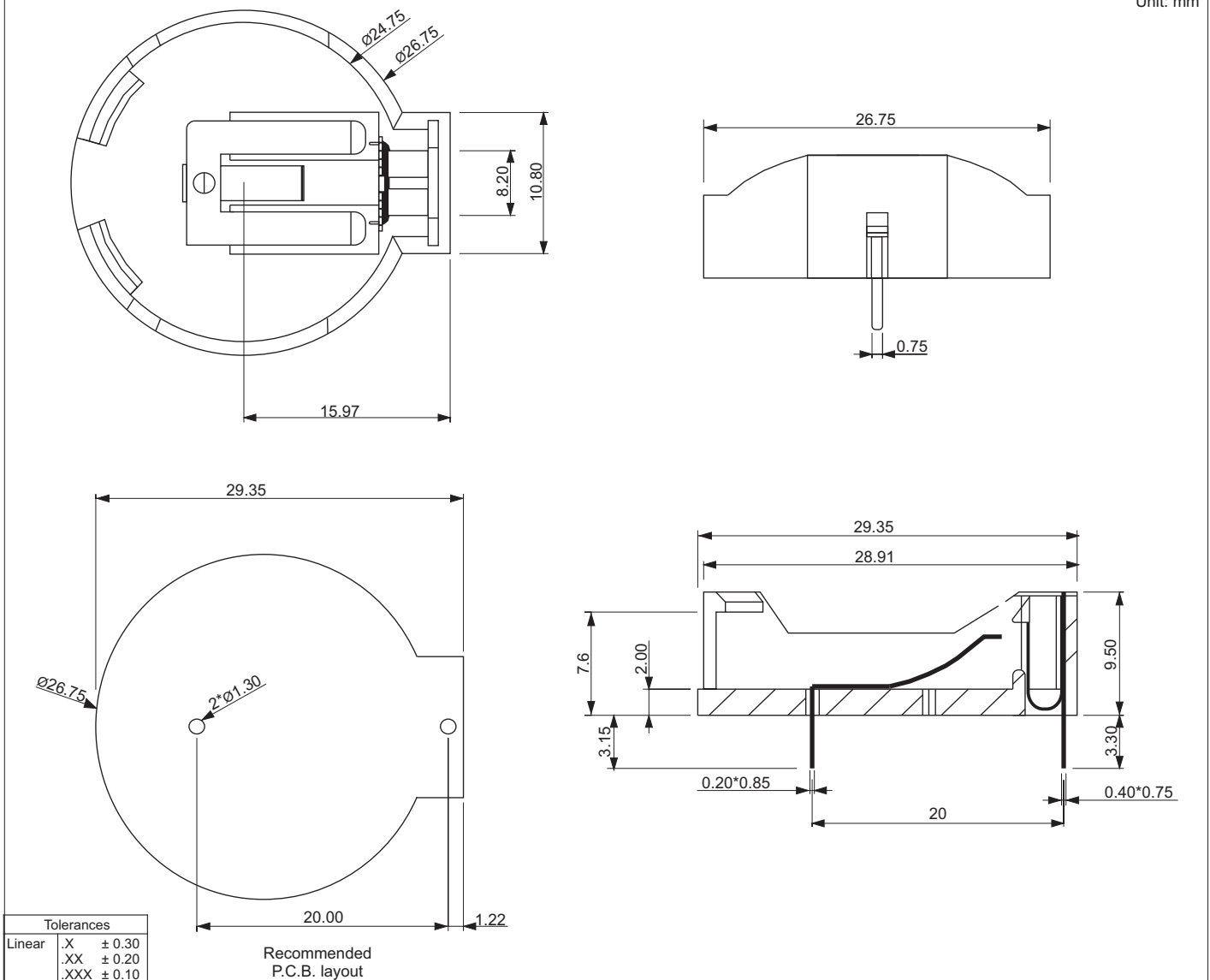

Part numbering guide

5100 — T

Series

Contact plating

T = Tin

* standard

