

61020 Series SMT RJ10 4P Top Entry Low Profile

General specifications

Insulator material	High temperature plastic, UL94V-0
Contact material	Phosphor bronze
Current rating	1.5 A
Voltage rating	125 VAC
Contact resistance	30 mΩ max.
Insulator resistance	1000 MΩ min.
Dielectrical withstanding	1000 VAC for 1 min
Operating temperature	-40 °C to +85 °C
Soldering	JEDEC lead free reflow soldering process
Durability	750 cycles

Mating parts series



RoHS
compliant

Mechanical dimensions

Unit: mm

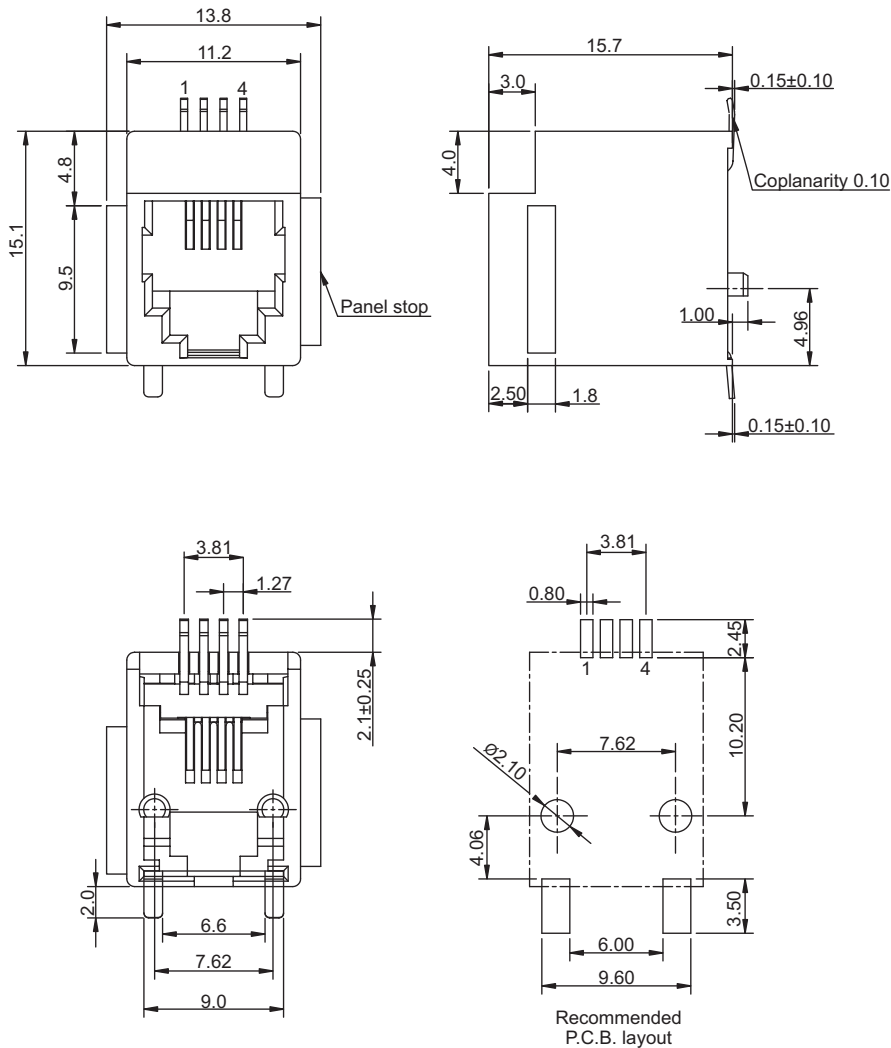

Tolerances		
Linear	X	± 0.25
	.XX	± 0.15
	.XXX	± 0.10

Part numbering guide

61010 — C — 1

Series

Contact plating

C = 3 μ" gold K = 50 μ" gold

D = 6 μ" gold

F = 15 μ" gold

J = 30 μ" gold

Panel stop

0 = w/o panel stop

1 = w/ panel stop

* standard

