

# 0650 Series

# Smart Card 8 Pin THT

## General specifications

Insulator material	High temperature thermoplastic, UL94V-0
Contact material	Phosphor bronze, plating: gold over nickel
Current rating	1 A
Voltage rating	30 V AC/DC
Contact resistance	100 mΩ max.
Insulator resistance	1000 MΩ @ 500 VDC
Dielectrical withstanding	500 VAC for 1 min
Operating temperature	-40 °C to +85 °C
Durability	100000 cycles
Soldering	Lead free wave soldering process

## Mating parts series



RoHS  
compliant

## Mechanical dimensions

Switch type: blade  
Operation: normally closed

Unit: mm

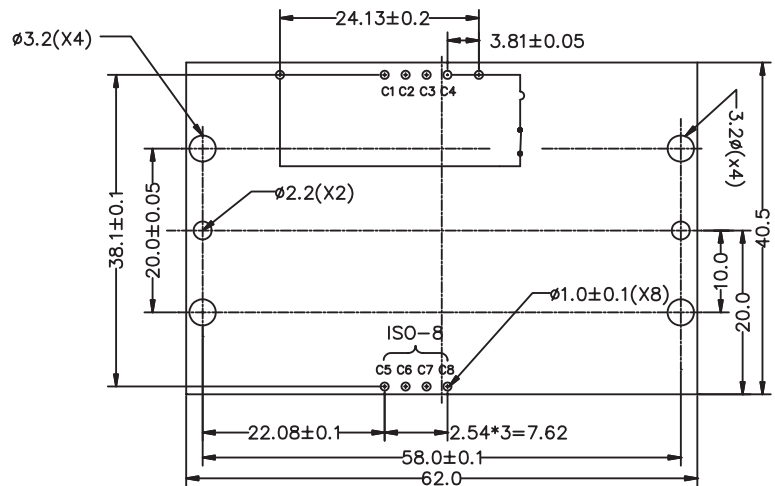
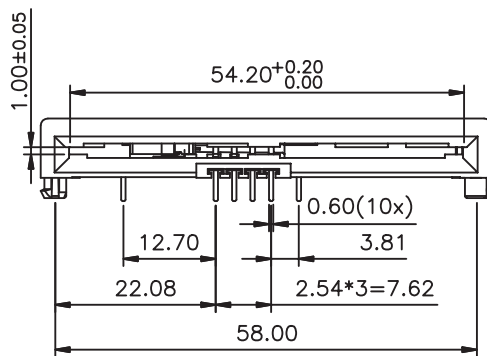
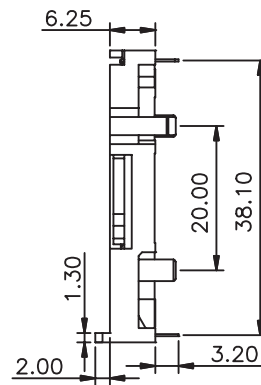
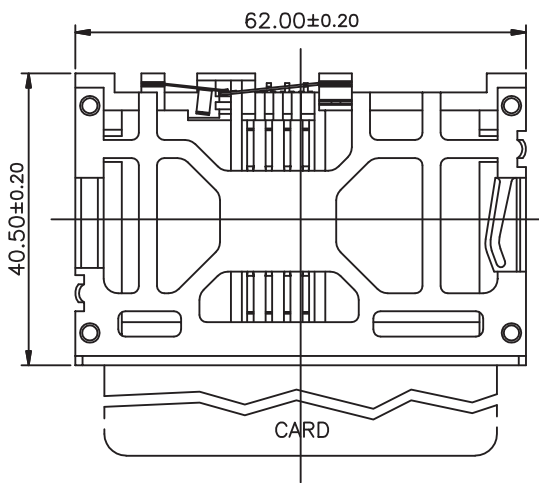

Recommended P.C.B. layout

Tolerances	
Linear	± 0.15

## Part numbering guide

0650	D	08	Y
Series	Contact plating D = 5 μ" gold	No. of data contacts 08 = 8	Packing Y = Tray

\* standard

