

2910 Series

0.50 mm LVDS Connector for TV/LCD

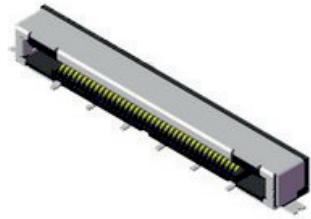

General specifications

Insulator material	High temperature plastic, UL94V-0
Contact material	Copper alloy, plating: gold
Shell	Stainless steel
Current rating	0.8 A
Contact resistance	40 mΩ max.
Insulator resistance	100 MΩ min.
Dielectrical withstanding	500 VAC for 1 min
Operating temperature	-40 °C to +80 °C
Soldering	Lead free wave soldering process

Mating parts series

2911

Mechanical dimensions

Unit: mm

2910H41

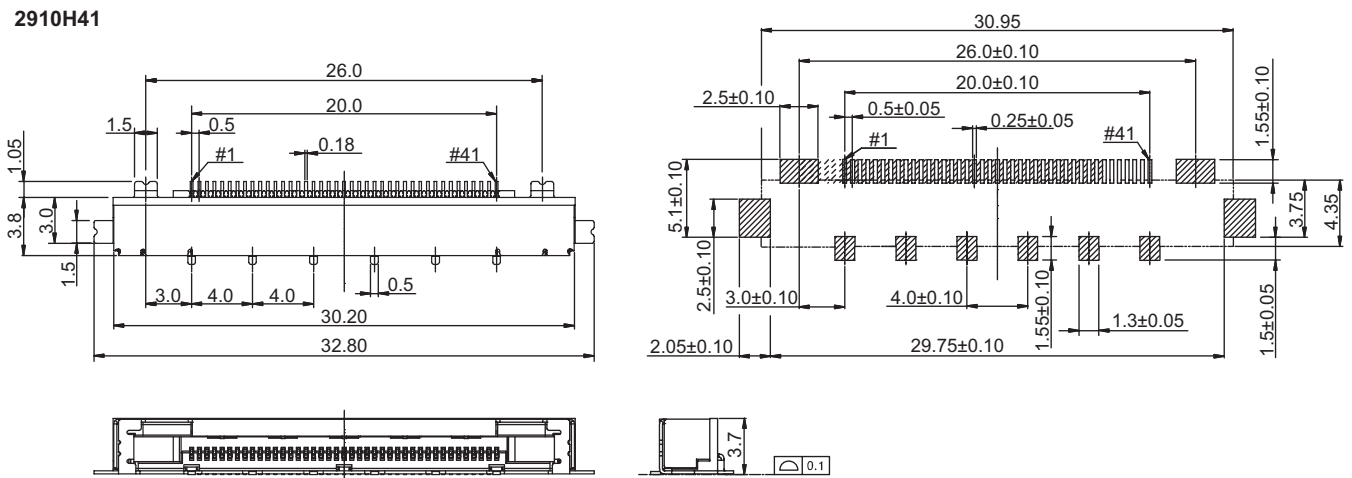

2910H51

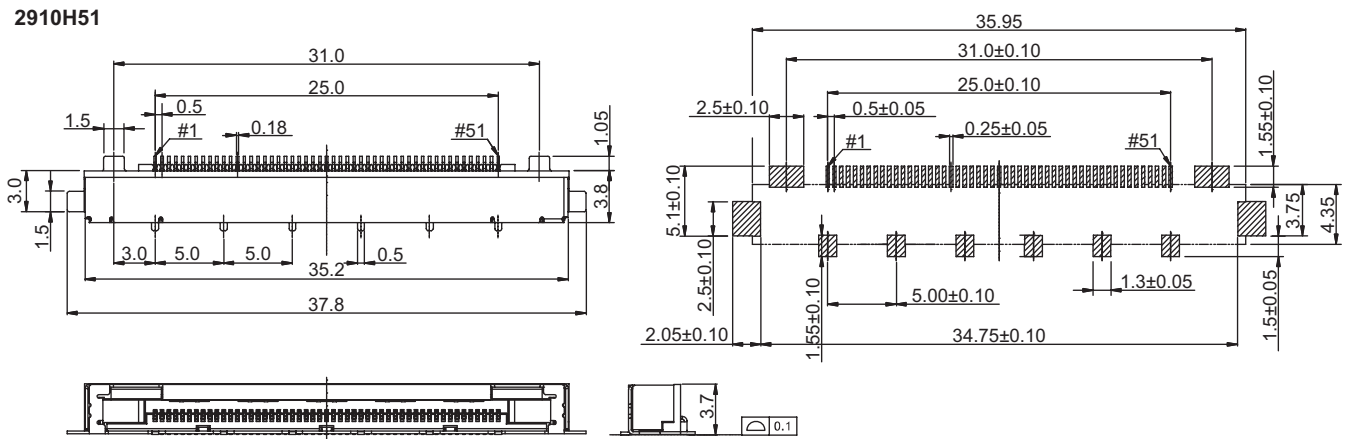

Tolerances

Linear	X	± 0.25
	.XX	± 0.20

Part numbering guide

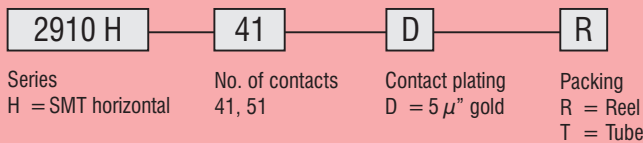

* standard

