

Rev. 1.0 15.06.2016 P/N.:  
2280V T/R

Tape and reel packing for 2280V

Telefon +49 (531) 23 14 2-0  
Telefax +49 (531) 23 14 2-55  
E-Mail info@nexus-de.com  
www.nexus-de.com

**NEXUS COMPONENTS**  
competence in electronics



Kd. Art.-Nr.: (Art.Nr.)

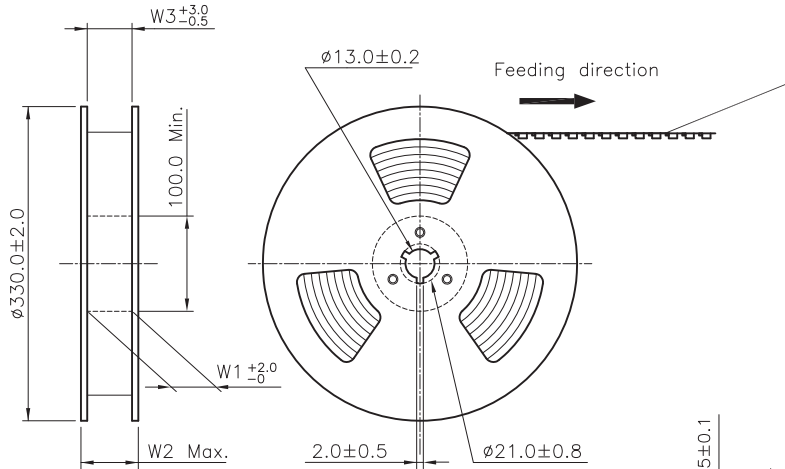

NOTES:

1. 10 sprocket hole pitch cumulative tolerance  $\pm 0.20$ mm.
2. Carrier camber not to exceed 1 mm in 100 mm.
3. Material :Transparent Anti-static Polysyrene.
4. All dimensions meet EIA-481-3 requirements.
5. Thickness :  $0.40 \pm 0.05$ mm.
6. Packing length per 22" Reel : 30.6 Meters.
7. Component load per 13" Reel : 800 pcs.

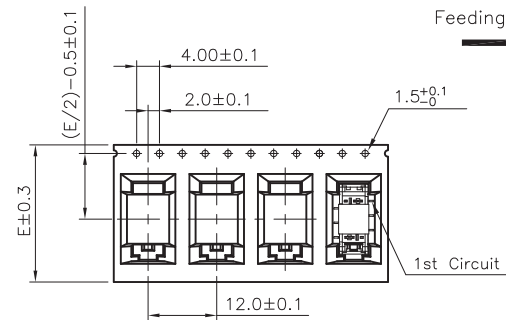
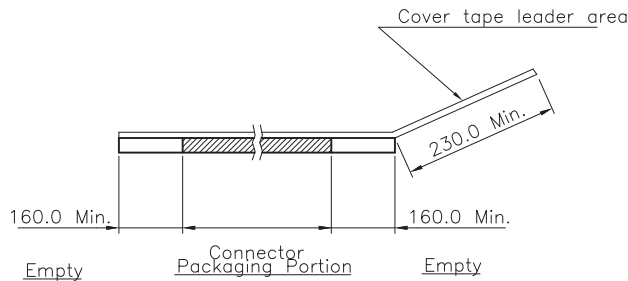

For With Latch Type

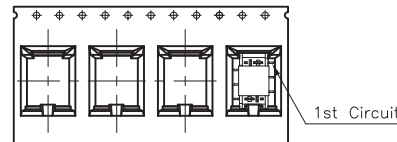

For Without Latch Type

WIDTH : 24 mm Carrier

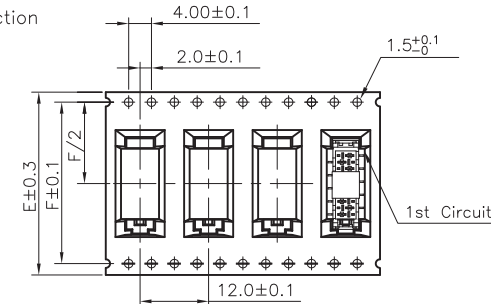

For With Latch Type

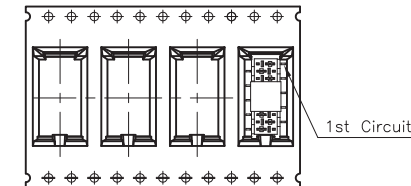

For Without Latch Type

WIDTH : 32.44.56 mm Carrier

| w/o Latch | w/ Latch | Dimension |       |      |      |      | Packing<br>(Reel/Cartron) |
|-----------|----------|-----------|-------|------|------|------|---------------------------|
|           |          | E         | F     | W1   | W2   | W3   |                           |
| 4~8       | 4~8      | 24.0      | -     | 24.5 | 30.5 | 24.5 | 9                         |
| 10~14     | 10       | 32.0      | 28.40 | 32.5 | 38.5 | 32.5 | 7                         |
| 16~22     | 12~20    | 44.0      | 40.40 | 44.5 | 50.5 | 44.5 | 5                         |
| 24~26     | 22~26    | 56.0      | 52.40 | 56.5 | 62.5 | 56.5 | 4                         |