

Series 3970

Optical Jack Toslink Transmitter

Material

Housing:	PBT, black
Spring:	SUS
Dust cap:	PBT, grey
Holder:	PBT, black
Optic component:	Phosphor bronze, tin plating
LED cover:	PBT, black

Device selection

IC material:	Si
LED peak:	650 λ_p (nm)
Operating voltage:	2.7 - 5.5 (Vcc)
Dissipation current:	5 (mA)
Fiber coupling light output:	min. -21 (dBm), max. -15 (dBm)



Features

High speed signal transmission (16Mbps NRZ signal)
Input TTL compatible, Power supply voltage: +3 to +5V

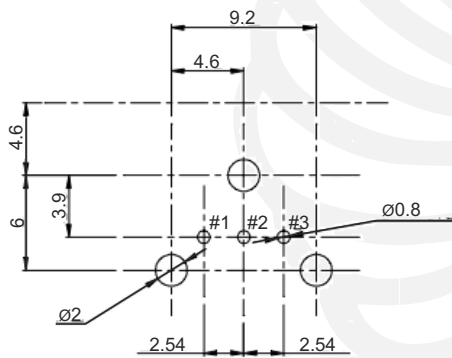

Recommended P.C.B. Layout

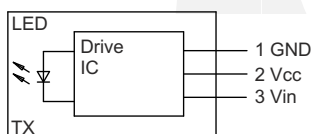
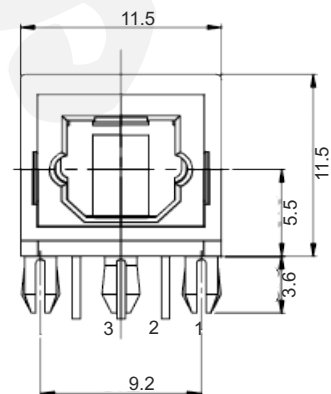
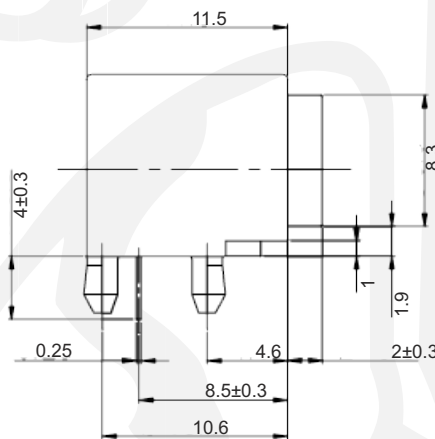
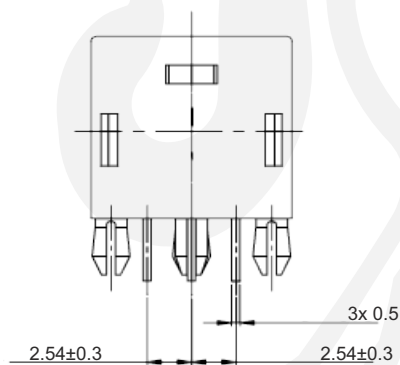

Tolerances	
Linear	0.1~2.0 ± 0.10 >2.0 ± 0.20

RoHS
compliant

All dim. in mm

3970 T

0

Y

Series
T = Transmitter

Option

Packing
Y = Tray

Absolute Maximum Rating (Ta = 25°C)

Parameter	Symbol	Rating	Unit
Supply Voltage	Vcc	-0.5 to 7	V
DC Input Voltage	Vin	Vcc + 0.5	V
Power Dissipation	P	70	mW
Storage Temperature	Tstg	-30 to 80	°C
Operating Temperature	Topr	-20 to 70	°C
Soldering Temperature	Tsol	260*	°C

* Soldering time ≤ 5s / 2 times.

Electro-Optical Characteristics

Parameter	Symbol	Conditions	Min.	Typ	Max.	Unit
Peak Emission Wavelength	λ_p	-	630	-	690	nm
Transmission Speed	T	16 Mbps NRZ signal	-	-	16	Mbps
Pulse Width Distortion	tw	16 Mbps NRZ Signal	-15	<+5	15	ns
Light Coupling Output*	Pi	*1	-21	-	-15	dBm
Dissipation Current	Icc	*1	-	5	10	mA
High Level Input Voltage	V _{IH}	*2	2.0	-	-	V
Low Level Input Voltage	V _{IL}	*2	-	-	0.8	V
Rise Time	t _r	*3	-	-	30	ns
Fall Time	t _f	*3	-	-	30	ns
Low → High propagation delay time	t _{PLH}	*3	-	-	100	ns
High → Low propagation delay time	t _{PHL}	*3	-	-	100	ns
Jitter time	t _j	*3	-	1.5	15	ns

* Light Input after APF should satisfy Pi range

Recommended Operating Conditions (Ta = 25°C)

Parameter	Symbol	Min.	Typ	Max.	Unit
Supply Voltage	V _{CC}	2.7	-	5.5	V
High Level input Voltage	V _{IH}	2.0	-	V _{CC}	V
Low Level Input Voltage	V _{IL}	0	-	0.8	V

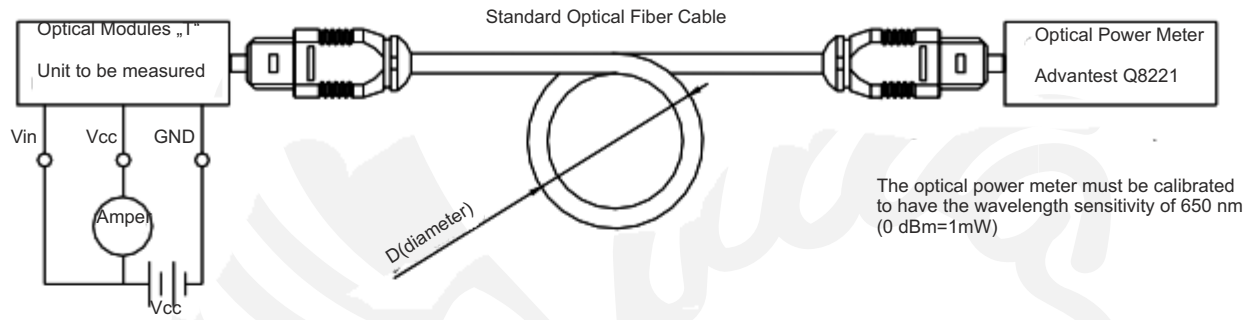
Measuring Method (1)**Conditions:**

1. V_{CC} = 5.0 V ± 0.05 V (DC)
2. If bundle up the fiber optic cable, make it into a loop with the diameter D ≥ 10cm

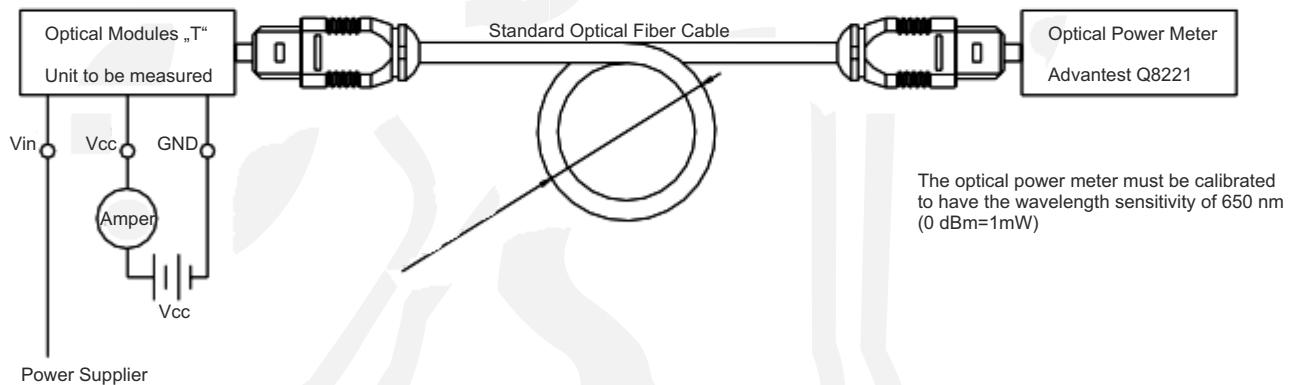
Measuring Method (2)**Conditions:**

1. V_{CC} = 5.0 V (State of Operating)
2. Amper Current Meter
3. V_{in}: to Power Supplier (or Signal Generator) (DC:0 - 5 V)

Julnput conditions and the method of judgement:

No.	Input conditions	Judgement
1	V _{in} ≥ 2.0V	-21 ≤ P _r ≤ -15 dBm, I _{CC} ≤ 10mA
2	V _{in} ≤ 0.8V	P _r ≤ -36 dBm, I _{CC} ≤ 10mA

All dim. in mm

Measuring Method (3)

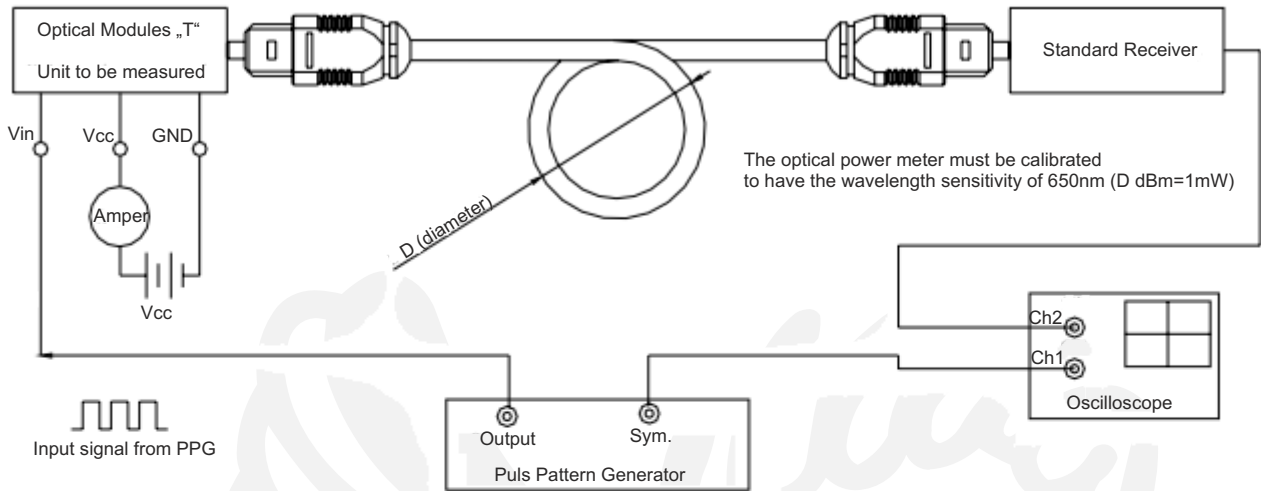

- Conditions
1. $V_{cc} = 5.0V$
 2. $V_{in} = 16$ Mbps NRZ duty 50 % signal. ($V_{ih} \geq 2.0 V, V_{il} \leq 0.8 V$)
 3. The probe of the oscilloscope must be more than $1M\Omega$ and less than $10pF$.
 4. When jitter is testing, the $V_{in} = 16$ Mbps PRBS signal ($V_{ih} \geq 2.0 V, V_{il} \leq 0.8 V$)

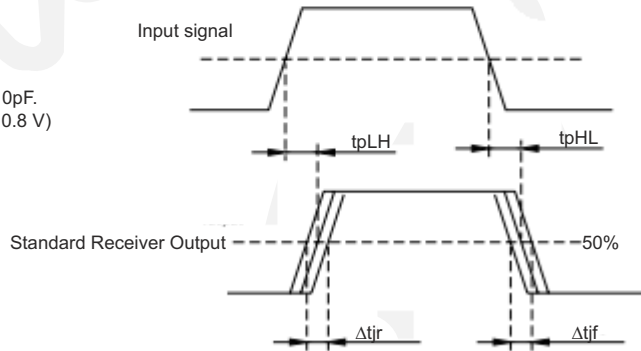

No.	Test Item	Symbol	Test Conditions
1	L to H pulse delay time	tpLH	It is defined by drawing in this page.
2	H to L pulse delay time.	tpHL	It is defined by drawing in this page.
3	Pulse width distortion	Δtw	$\Delta tw = tpHL - tpLH$
4	L to H Jitter	Δt_{jr}	Set the trigger on the rise of input signal to measure the jitter of the rise of output.
5	H to L Jitter	Δt_{jf}	Set the trigger on the rise of input signal to measure the jitter of the fall of output.

All dim. in mm



Reliability test

No.	Item	Test Condition	Samples (n) Defective (c)
1	High temp. storage	Ta = 80°C, 500h	n=22, c=0
2	Low temp. storage	Ta = -30°C, 500h	n=22, c=0
3	High temp. operation	Ta = 60°, Vcc=5.0V ON, 500h	n=22, c=0
4	High temp. & Humidity storage	Ta = 40°C, 90%RH, 500h	n=22, c=0
5	Temp. Cycling	Ta = -30°C ~ +80°C (30min) (30min) 20 cycles	n=22, c=0
6	Shock	Acceleration 1000m/s ² , pulse width 6 ms, X,Y,X/ 3 times each direction	n=11, c=0
7	Vibration	10 ~ 55 Hz/sweep 1 min. amplitude: 1.5mm, X,Y,Z/2 hour each.	n=11, c=0
8	Terminal Strength (tension)	Weight: 5N, 30sec./each terminal	n=11 c=0
9	Terminal Strength (bending)	Weight: 2.5N (in the axial direction),0°-90°-0°, 2times/each terminal 2times/each terminal	n=11, c=0
10	Soldering Heat	Ta=260°C±5°C, 5sec., 2 times. Dip the area at adistance of more than 1.6mm from the element base, Ta=350°C±5°C, 3sec, 1 time. Dip the area at a distance of more than 7mm from the lens.	n=11, c=0
11	Solder ability	Ta=245°C±5°C, 5 sec. used a rosin flux.	n=11, c=0
12	Repeated Operation	After 500 cycles of mating and un-mating, the following value shall be satisfied.	n=11, c=0
13	Repeat open/close operation of shutter	After 1000 times the function shall be no trouble. Shutter shall be no damage.	n=11, c=0

If there is any doubt about the results Ambient temperature: 5°C ~ 35°C, relative humidity : 45% ~ 85%.
In the test 1 to 5, 10 above the transmitter shall be subjected to standard atmospheric conditions for 2 hrs.
after which measurement shall be made.

Judgement criteria

In the testing items of 1-7 and 10 electro-optical characteristics shall be satisfied in following:

Upper specification limit $x \leq 0.8$ Lower specification limit $x \geq 1.2$	Upper specificatin limit $x \leq 1.2$ Lower specification limit $x \geq 0.8$	Upper specification limit $x \leq 1.2$ Lower specification limit $x \geq 1.2$
Current consumption (Icc) High level input voltage (V _{IH}) Low level input voltage (V _{IL}) Low to high propagation delay (t _{PLH}) High to low propagation delay (t _{PHL}) Jitter time (Δt_j)	Fiber coupling Light output (P _r)	Pulse width distortion (Δt_w)

Test No. 8 & 9: Without cracks on the terminal.

Test No. 11 : A new uniform coating of solder shall cover a minimum of 75% of the surface be immersed.

Test No. 12 : Mating force $\leq 39.2N$; 5.9N \leq un-mating force $\leq 39.2N$.

All dim. in mm

