

# 3864 Series

# USB A-Type Socket Reverse w / Back Cover

### General specifications

Insulator material	High temperature thermoplastic, UL94V-0
Contact material	Copper alloy
Current rating	1.5 A
Voltage rating	250 VAC
Contact resistance	30 mΩ max.
Insulator resistance	1000 MΩ @ 500 VDC
Dielectrical withstanding	500 VAC for 1 min
Operating temperature	-55 °C to +85 °C
Soldering	Lead free wave soldering process
Durability	1500 cycles

### Mating parts series

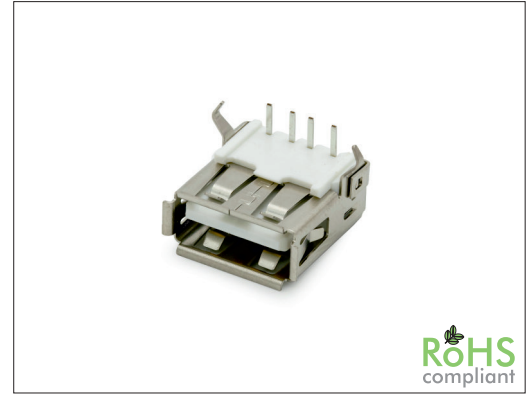

### Mechanical dimensions

Unit: mm

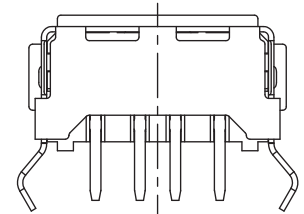
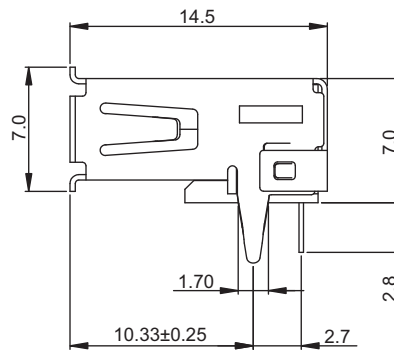
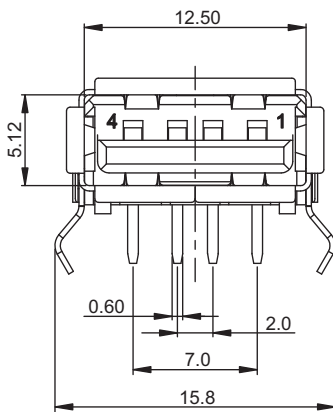
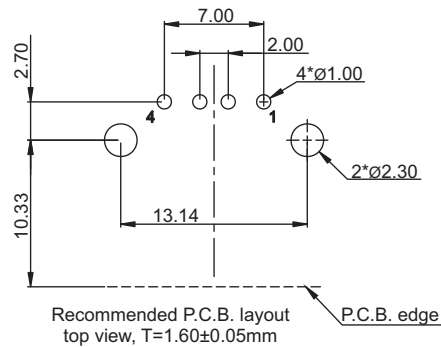
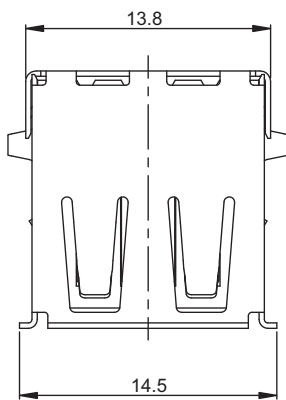

Tolerances	
Linear	.X ± 0.250
	.XX ± 0.150
	.XXX ± 0.075

### Part numbering guide

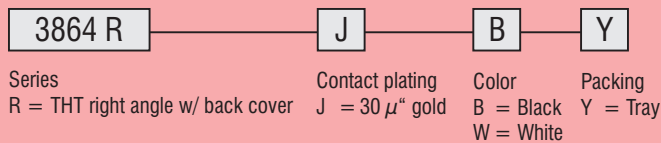

\* standard



# 3864 Series

# USB A-Type Socket Reverse

## General specifications

Insulator material	High temperature thermoplastic, UL94V-0
Contact material	Copper alloy
Current rating	1.5 A
Voltage rating	250 VAC
Contact resistance	30 mΩ max.
Insulator resistance	1000 MΩ @ 500 VDC
Dielectrical withstanding	500 VAC for 1 min
Operating temperature	-55 °C to +85 °C
Soldering	Lead free wave soldering process
Durability	1500 cycles

## Mating parts series

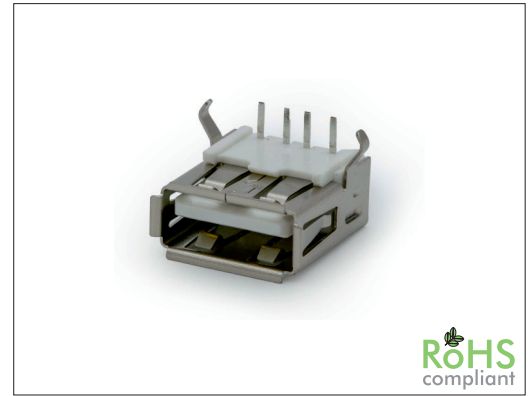

RoHS  
compliant

## Mechanical dimensions

Unit: mm

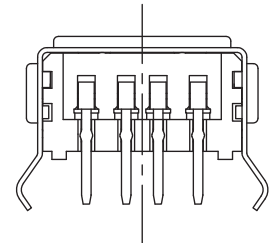
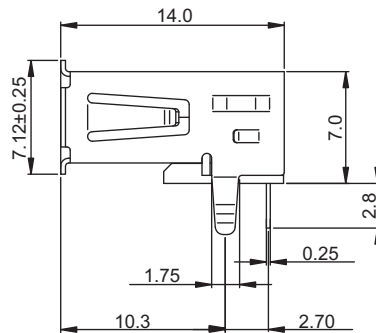
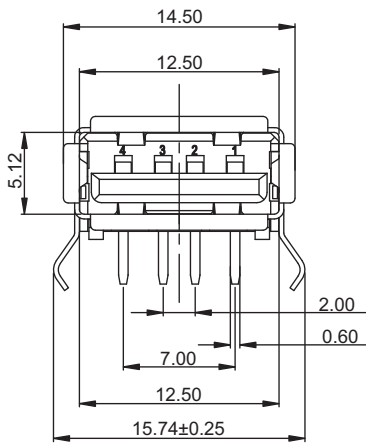
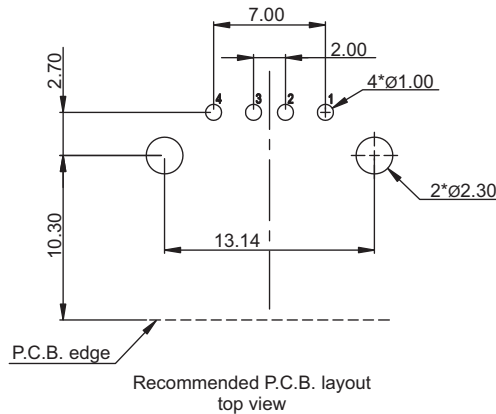
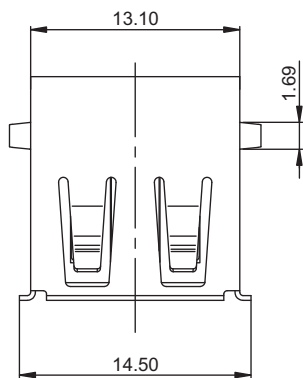

Tolerances		
Linear	.X	± 0.250
	.XX	± 0.150
	.XXX	± 0.075

## Part numbering guide

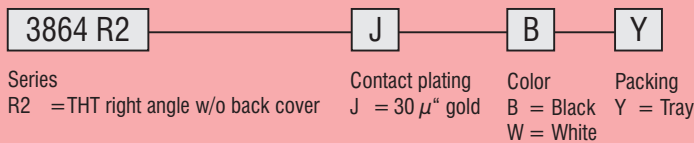

\* standard

