

2854 Series

0.50 mm SMT FPC ZIF Socket Up Contacts

General specifications

Insulator material	LCP, UL94V-0
Contact material	Phosphor bronze
Current rating	0.5 A
Voltage rating	50 V AC/DC
Contact resistance	30 mΩ max.
Insulator resistance	100 MΩ min.
Dielectrical withstanding	250 VAC for 1 min
Operating temperature	-25 °C to +85 °C
Soldering	JEDEC lead free reflow soldering process

Mating parts series

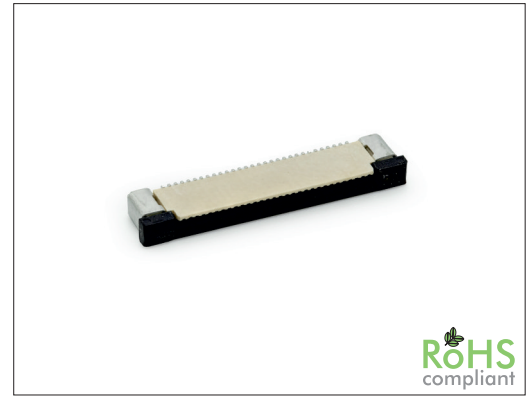

RoHS
compliant

Mechanical dimensions

Unit: mm

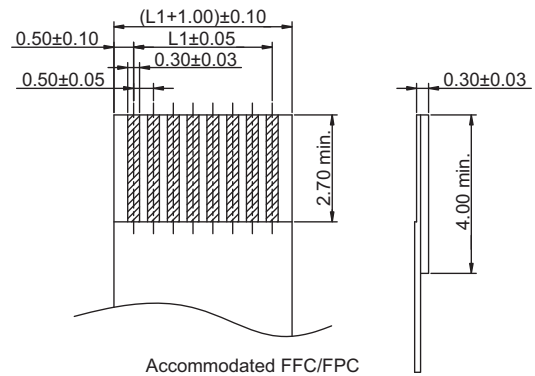
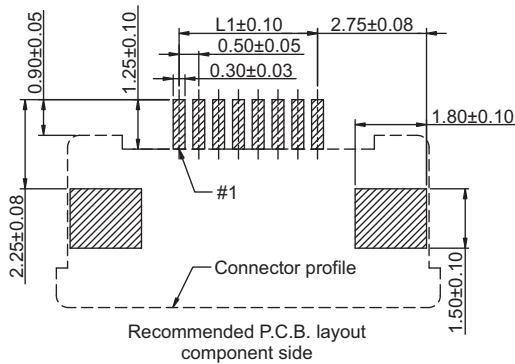
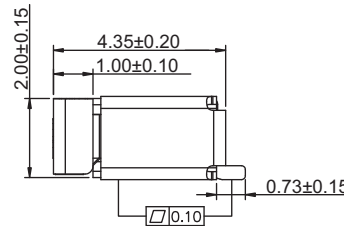
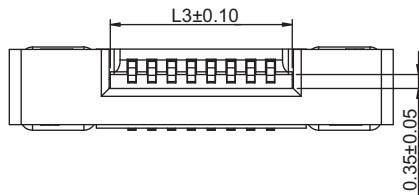
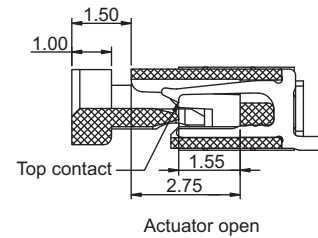
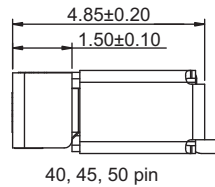
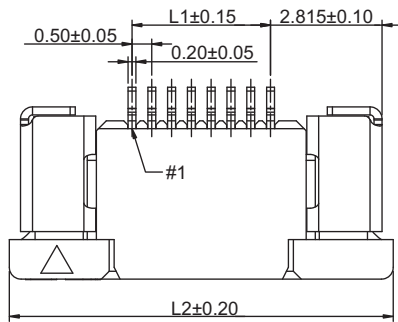

L1 = (No. of contacts - 1) x 0.50
 L2 = No of contacts x 0.50 + 5.70
 L3 = L1 + 1.10

Tolerances

Linear	X	± 0.25
	.XX	± 0.15
	.XXX	± 0.05

Part numbering guide

2854 UJ	04	T	R
Series UJ = SMT right angle up contacts	No. of contacts 04 to 51	Contact plating T = Tin* B = Flashgold C = 3 μm gold	Packing R = Reel

* standard

