

3800 Series

SMT Micro USB 5 Pin Socket

General specifications

Insulator material	LCP, UL94V-0, color: black
Contact material	Brass
Current rating	1.0 A @ pin 2, 3, 4, 1.8 A @ pin 1, 5
Contact resistance	30 mΩ max.
Insulator resistance	100 MΩ min.
Dielectrical withstanding	100 VAC for 1 min
Operating temperature	-55 °C to +105 °C
Soldering	JEDEC lead free reflow soldering process
Durability	6000 cycles

Mating parts series

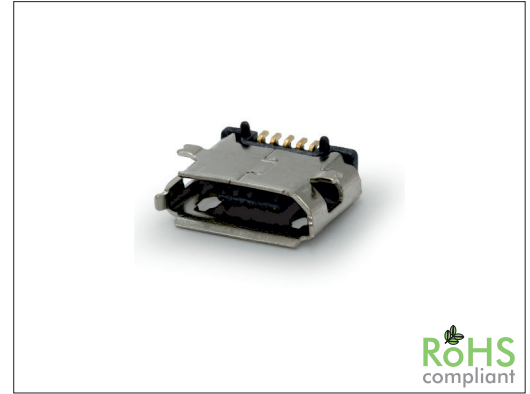

Mechanical dimensions

Unit: mm

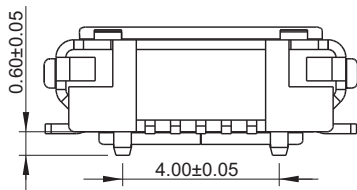
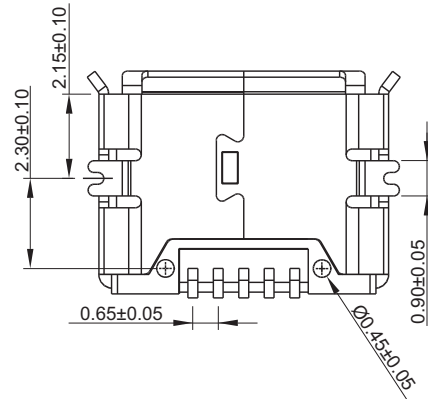
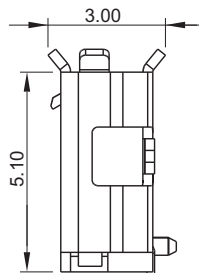
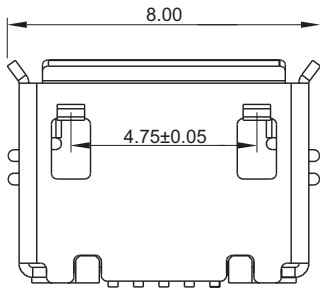
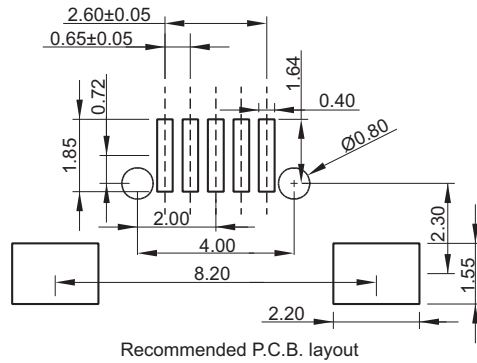
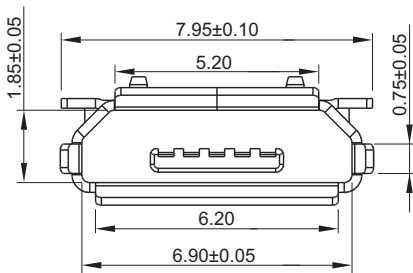

Tolerances

Linear	X.	± 0.50
	.X	± 0.30
	.XX	± 0.20
	.XXX	± 0.10

Part numbering guide



Series Contact plating Position peg Packing
 H = SMT horizontal B = Flashgold 1 = w/ peg R = Reel

* standard

