

Rev. 1.0 20.06.2016

P/N.:

64211C0-Reel

Tape & Reel Packing

Telefon +49 (531) 23 14 2-0  
 Telefax +49 (531) 23 14 2-55  
 E-Mail info@nexus-de.com  
 www.nexus-de.com

**NEXUS COMPONENTS**  
 competence in electronics



Kd. Art.-Nr.: (Art.Nr.)

**MATERIALS:**

- 1.CARRIER-PS (0.50mm THICK TAPE).
- 2.REEL-2mmTHICK PLASTIC WHEEL.
- 3.COVER TAPE-PE (0.045mm~0.12mm THICK TAPE).

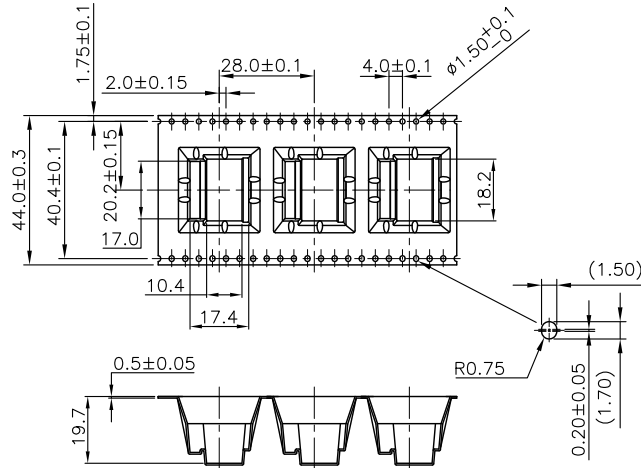

**NOTES:**

1. 10 EMPTY CAVITIES FOR BOTH OF TOP AND BOTTOM OF THE CARRIER.
2. 120 PCS PRODUCTS BE PACKAGED ON REEL.
3. 軸外保護帶 361-319.

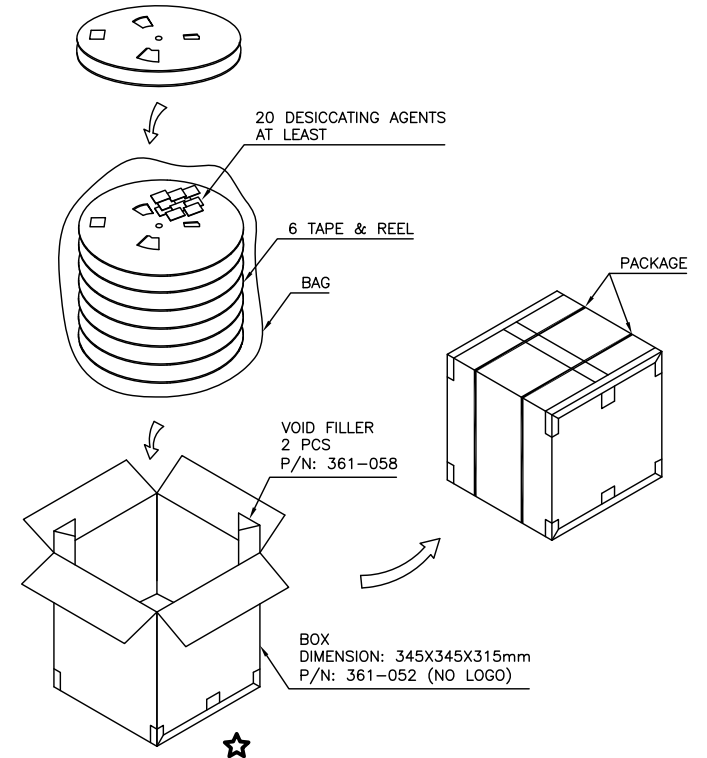
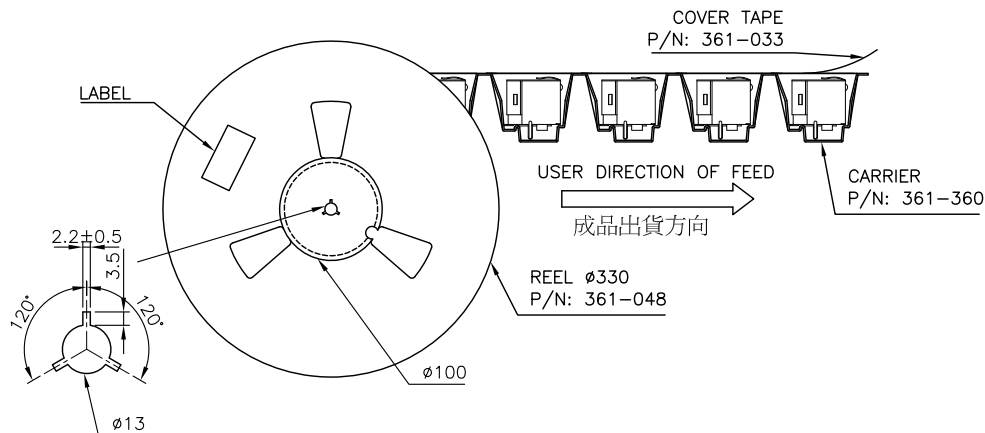
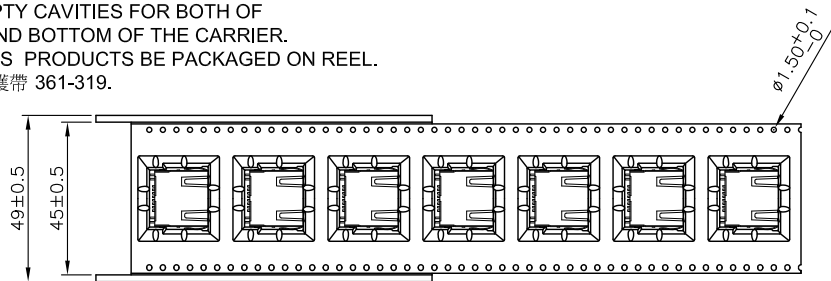

**RoHS**  
 compliant

THIS DRAWING IS A CONTROLLED DOCUMENT.  
 DO NOT SCALE DRAWING.

DIMENSIONS: MM	TOLERANCES UNLESS OTHERWISE SPECIFIED:
	0 PLC ± -
	1 PLC ± 0.30
	2 PLC ± 0.20
	3 PLC ± 0.10
	ANGLES ± -

THIRD ANGLE PROJECTION